

PIERCE

PULLING FOR YOU

OWNER'S MANUAL
BALE SPIKES
ABS1K / ABS2K



REGISTER YOUR PRODUCT!

We want to serve you.
Please register your product at
www.piercearrowinc.com/register.

Why register?

- product updates via email
- maintenance reminders via email
- quick technical service help if you encounter a problem

DISCLAIMER

The Pierce bale spike and spears are not covered under any warranty against bending, breakage, or any other damage. Bale spikes and spears, when used properly in pairs, with the hay bale fully impaled on the spikes for the purpose of handling and transporting hay bales, have proven to be very reliable for their intended purpose.

Expected spike and spear failures have occurred when used improperly: if used to lift tractors, pull posts, transport more than one bale per pair of spikes, lift a bale of hay on the bottom of the stack with hay bales stacked on top, used as rock pickers, or transporting bales that are not fully impaled on the spear and resting against the framework holding the spear.

Care should be taken not to allow vehicle voltage to go below 9V because the vehicle's computer system will go into fail safe mode.

SAFETY WARNINGS

- Never drive your vehicle with the spears in the down position.
- Always lift hay bales with both hay spears. Damage will occur when the bale is lifted with one spear.
- Occasionally check to make sure your bolt or pin is properly secured in the spear collar.
- Picking up bales wider than the rear opening of your truck bed may result in truck damage.

SPECIFICATIONS

ABS1K Weight	290 lbs	ABS2K Weight	385 lbs
ABS1K Capacity	2,500 lbs	ABS2K Capacity	2,500 lbs
ABS1K Dimensions		ABS2K Dimensions	

PARTS LIST

PRE-ASSEMBLED BASE

ABS1K	ABS2K	PART DESCRIPTION	QTY
ABS1BASE	ABS2BASE	base	1
ABS1HINGEV2	ABS2HINGEV2	hinge	1
ABS001	--	double collar <i>(ABS1K only)</i>	1
--	ABS2CROSSM	cross member <i>(ABS2K only)</i>	1
ACOPL		pump cover	1
PM-3554-0131		Bucher 2-way pump	1
HCL-3016		3x16 welded cylinder	1
ABSHNB		8' bale spike harness	1
ABS1H		hose for bale spike	2
14490		90° fitting for pump	2
P19414		90° fitting for cylinder	2
ASTC905		dust cover for quick connect	1
ABS1SPEAR		spear for bale spike	2

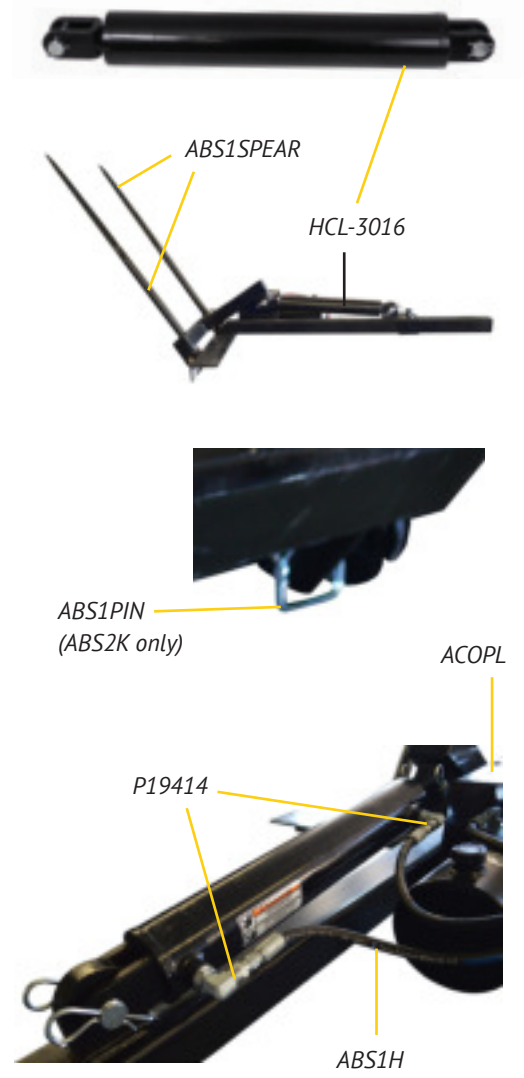

PARTS BAG

Manual		bale spike manual	1
CP077K		2 button remote	1
76631		200 amp breaker	1
ABSHB4		20' truckside harness	1
PS006		4 gauge battery terminal	4
ABS1SPBOLT	--	bolt and nut for spear <i>(ABS1K only)</i>	2
--	ABS1PIN	pins for spears <i>(ABS2K only)</i>	2
5010		7/16" grommet	2
9629		8" black zip tie	12
31816		#10x2" self tapping screw	2
1131813		#10x1" self tapping screw	2
ASTC905		dust cover for quick connect	1



INSTALLATION

ABS1K

1. In order for the Pierce ABS1K Bale Spike to be installed, a 2 5/16" trailer ball must be installed between 45"-52" from the center of the ball to the rear of the bed.
2. Remove your tailgate by lowering it, then remove the side straps. Lift your tailgate 30 degrees. It should come loose from its hinge point.
3. Remove the sliding collar. Place the bale spike in the truck bed with the 3" square tubing resting on top of the gooseneck ball. Slide the bale spike forward until the hole on the underside of the bale spike's 3" square tubing drops over the ball.
4. Pull the bale spike towards the rear of the truck until the spike drops down to a seated position. The bottom of the angle iron must be seated against the rear of the truck bed.
5. Install the sliding collar with the notch on the bottom facing the trailer ball and slide towards the ball. Once the collar is firmly against the trailer ball, tighten the bolt being careful not to allow any space between the angle iron frame and the rear of the bed.
6. Wire your CP077K remote. *(see Remote Wiring on pages 5 for instructions)*

Note: If this is to be installed on a bed with a recessed ball, like most flat beds, your install will require our included double collar to reach the trailer ball. This installs the same as our standard collar but with the extension facing down and the bolt facing up.

ABS2K

1. Remove your tailgate by lowering it, then remove the side straps. Lift up your tailgate 30 degrees. It should come loose from its hinge point.
2. Remove the adjustable crossmember from the frame of the bale spike. It should be installed in the truck bed from 33" to 56" from the rear of the truck bed.
3. Attach the crossmember to the truck using at least two 1/2" grade 8 bolts. These should connect directly to the truck frame by drilling through the top frame flange or attaching with brackets (not included).
4. Slide rectangular tubing runners into the crossmember collars until the angle iron rests on and is against the rear of the truck bed. Tighten both collar locking bolts being careful not to allow any space between the angle iron frame and the rear of the bed.
5. Wire your CP077K remote. *(see Remote Wiring on pages 5 for instructions)*

INSTALLATION *(continued)*

ELECTRICAL CONNECTIONS

1. Quick connect power plugs are used for connecting the electrical power to the bale spike. These plugs are mated and keyed to prevent reverse polarity connection.
2. One plug comes connected to the unit. The other plug may be mounted to any flat surface with the supplied self-drilling screws. On most factory beds, the best location is inside the bed just ahead of the fender around 6"-10" below the top of the rail.
3. To mount the plug, drill two 9/16" holes vertically, with about a 1" space between the two holes. Snap the two supplied plastic grommets into the holes.
4. Feed the two power cables on the quick connect power plug through the drilled holes and route them along the inside of the truck frame to the battery. Take care to avoid all exhaust parts, sharp edges and any moving parts. Secure the cable with zip ties at least every 18".
5. One of the two power cables will be marked with red tape or red insulation. That cable needs to be attached to the positive terminal of the battery with the 200 amp breaker in line as close to the battery as possible. When running the red (+) cable to the battery, extreme care must be taken to make sure the cable is placed in a safe secure place to guard against rubbing and damaging the cable. The quick disconnect should then be disconnected when not in use.
6. The black (-) cable will need to be connected directly to the negative terminal of the battery. It is necessary to make the direct ground connection, as you may not get the best connection when wiring the ground to the frame. This will make the bale spike run stronger and also prolong the life of your equipment.

BREAKER CONNECTIONS

Installation of a breaker (*figure 2*) is required for your equipment's safety. We use a 200 amp breaker.

The breaker has two positive connections that connect to the pump's solenoid and the vehicle's battery. Attach the jumper cable's ground clamp to a good ground source to ground your pump. Attach the hot clamp directly to the post on the top of your motor, careful not to touch any metal parts. If your motor does not run or runs sluggish, it will need to be replaced.

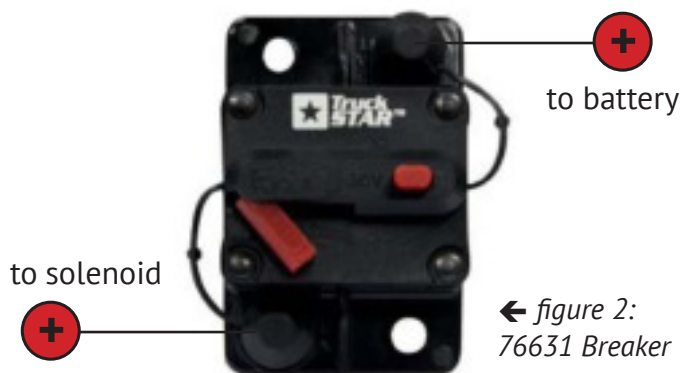

← *figure 2:*
76631 Breaker

FLUID

1. Fill the pump with fluid 2"-3" from the top of the reservoir.
 2. After the electrical power has been connected operate the pump cycling the spears to the full down and then to the full up position.
 3. Refill the reservoir (step 1). Continue up/down cycle until the level is constant.
- Note:** Always check and add fluid with the spikes in the up position. We recommend using any good grade hydraulic oil or dexron III automatic transmission fluid (do not mix).

INSTALLATION (continued)

REMOTE WIRING

1. Use two 9/16" wrenches to remove the pump cover by unbolting the two 3/8" nuts.

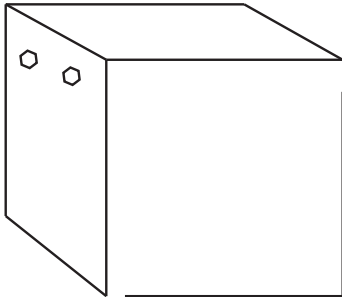

2. Wire the remote to the pump according to the diagram.

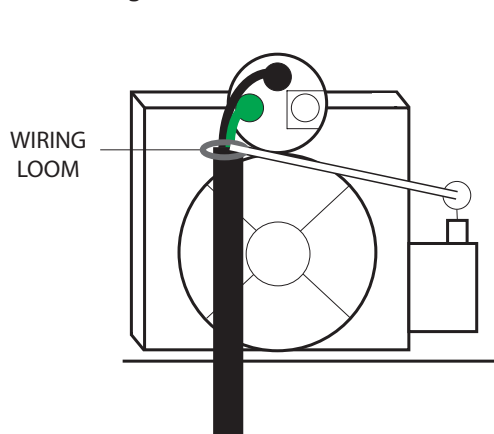

3. Run the remote cord through the supplied loom clamp. Bolt the loom clamp down using the solenoid mounting screw.

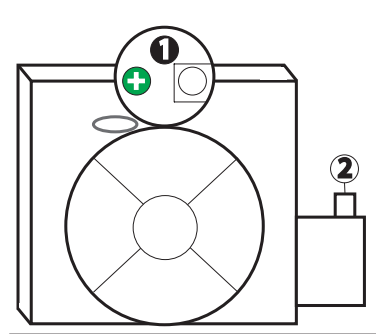

- + Remote Positive to the Solenoid
- 1 Remote F1 to the Solenoid
- 2 Remote F1 to the Coil

4. Reinstall the pump cover using two 9/16" wrenches.

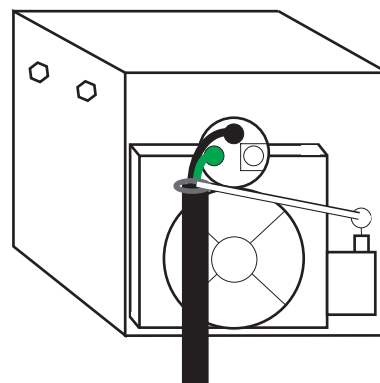

← figure 1:
PIERCE CP077K
Two-Function
Wired Remote
for use with
ABS1K and
ABS2K

OPERATION

1. If power has been disconnected, reconnect power.
2. Push the down button to lower and push the up button to return the spears to the up position. (see figure 1)

WIRING DIAGRAM

PM3554 Bucher Pump
ABS1K / ABS2K Replacement Pump

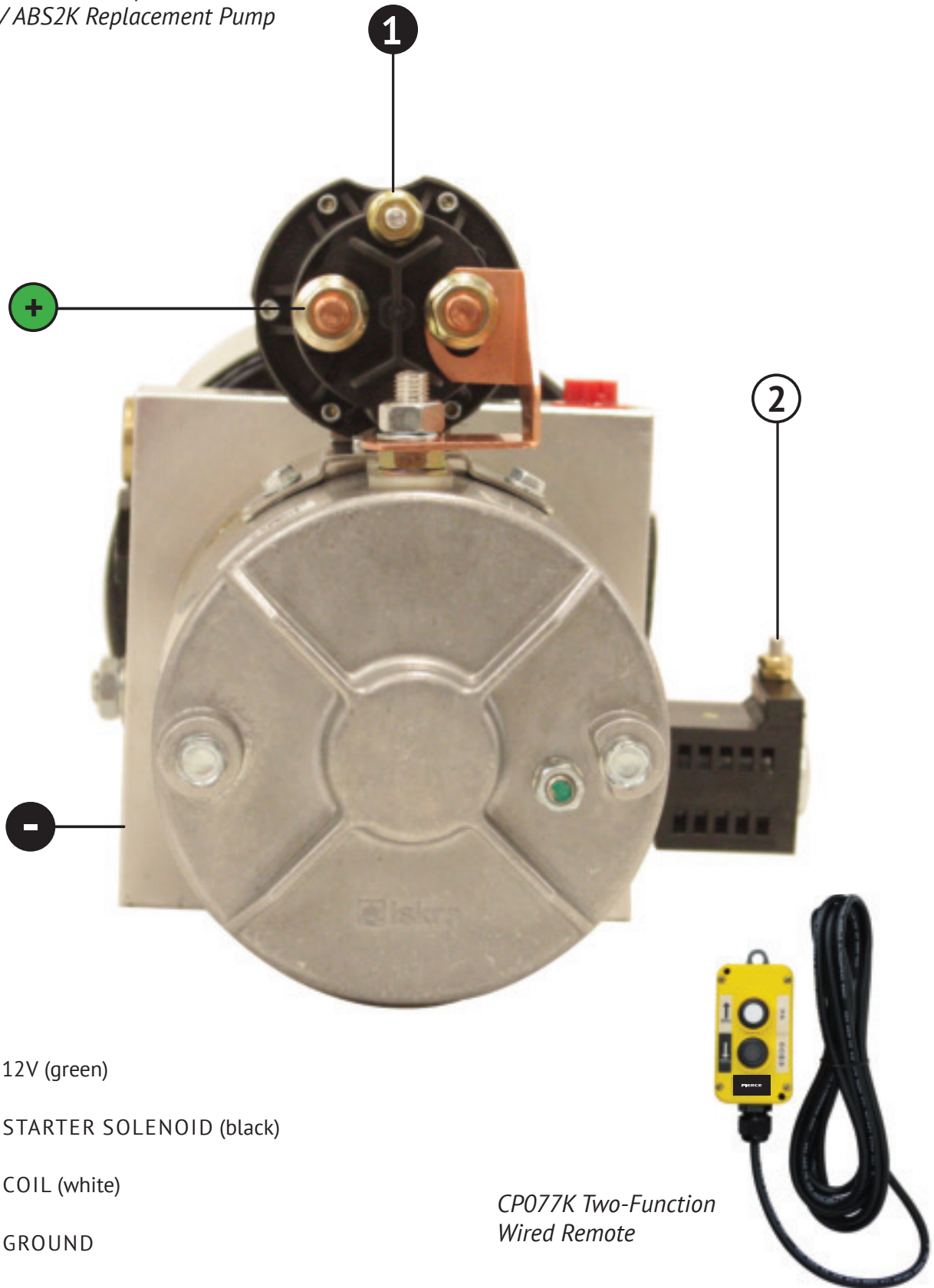

- +** 12V (green)
- 1** STARTER SOLENOID (black)
- 2** COIL (white)
- GROUND

CP077K Two-Function
Wired Remote

BUCHER DC POWER UNIT MAINTENANCE

- Oil level and fluid condition should be checked every 3 months. Oil should be changed yearly.
- Battery cable connections should be inspected for corrosion every 2 months.
- All electrical connections at power unit should be inspected for corrosion and cleanliness every 2 months. Check tightness of nuts on motor stud and motor solenoid.
- Inspect condition of all electrical wiring every 6 months. Wire should be free from cracks or damage to insulation.
- Inspect condition of filler/breather cap every 6 months. If foam is missing or dirty replace the cap.

TROUBLESHOOTING

If the bale spike does not seem to be operating properly, start by checking the fluid level in your reservoir. The reservoir should have fluid 2-3 inches from the top of the fill hole.

Next, check your wiring. Loose, frayed, and especially corroded wires can prevent your equipment from getting adequate power, and even damage your electrical parts. Corroded battery terminals will cause malfunctions.

IF THE REMOTE FUNCTIONS IMPROPERLY

Disconnect the remote. Use a small test wire to jump from the hot post on your solenoid to the small actuator post on your solenoid. This should raise your spears. To lower your spears, you will need two wires. Both wires will connect to the hot post on your solenoid. The end of one wire needs to connect to the plastic coil on the side of your pump. Then touch the other wire to the small actuator post on your solenoid. If your spears raise and lower properly, you need to replace your remote.

IF THE SOLENOID FUNCTIONS IMPROPERLY

Disconnect your remote. Use a small test wire to jump from the hot post on your solenoid to the small actuator post on your solenoid. If you cannot hear a strong audible click coming from your solenoid, it will need to be replaced.

When you apply power to the solenoid actuator, check the voltage at the motor post using a 12 volt test meter. Sometimes a solenoid will click but the contacts inside may be inadequate.

WEATHERIZE YOUR BALE SPIKE

Before temperatures decrease, clean the filters and change the fluid to eliminate crystallization.

What is the weight limit of Pierce bale spikes?	Pierce bale spikes have a lifting capacity of 2,500 lbs.
What is the difference between the ABS1K and ABS2K?	The ABS1K installs directly over a gooseneck ball, while the ABS2K bolts into the truck bed so you can haul trailers while the spike is mounted. Both units come equipped with removable bale spears.
How are Pierce ABS1K bale spikes installed?	If you choose the ABS1K, you must have a gooseneck ball on the back of your bed. Remove your tailgate. Place the bale spike in the bed making sure the square tubing rests over the gooseneck ball and the angle iron frame is against the rear of the truck bed. Tighten the provided collar against the gooseneck ball.
How are Pierce ABS2K bale spikes installed?	Before installing the bolt in spike, remove your tailgate. The crossmember must be bolted to the bed between 33" - 56" from the rear of the bed. Use half inch grade eight bolts to secure the spike to the bed and top frame flange. Slide the provided rectangular tubing through the crossmember collars until the angle iron rests against the rear of the bed. Tighten the bolts to complete the installation.
How long will my bale spike hold up?	With proper maintenance, a 20 year life could be expected. We routinely service Pierce bale spikes manufactured in the early 1980s.
How long is the spike's lift cycle?	Fifteen to twenty seconds is normal.
Where do I mount the pump?	The pump comes installed on the driver's side of the bale spike. We include a pump cover for added protection.
What kind of hydraulic fluid do you recommend using?	We recommend either Dexron or type F automatic transmission fluid. A lightweight hydraulic fluid also works well. We do not recommend using universal tractor fluid in winter weather. NOTE: Hydraulic oil is NOT compatible with transmission fluid, and different types of hydraulic oils and transmission fluids may not be compatible with each other.
How often should I maintain the pump?	Check the oil and fluid levels every three months. Oil should be changed yearly by removing the tank, cleaning the filter screen, and disconnecting the hydraulic lines. Manually operate the cylinder to expel all fluid. Refill the tank with Dexron or type F automatic transmission fluid.
I've noticed the pump runs slower in winter. What should I do?	In freezing weather, moisture can block the intake screen inside the pump tank. Clean the pump's filters and change the fluid to eliminate crystallization.
Where are Pierce bale spikes made?	Our shop is located in Henrietta, Texas where we assemble, weld and service our bale spikes.

LIMITED WARRANTY

Pierce Arrow Inc. warrants that the goods, equipment, and merchandise manufactured by Pierce Arrow Inc. are free from defects in material and workmanship. The limited warranty includes replacement or repair of defective mechanical and electrical parts for a period of one year from the date of shipment by Pierce Arrow Inc.

OBTAINING WARRANTY SERVICE

Pierce Arrow Inc. must be notified of any defect before repair or replacement may be granted. The merchandise must be delivered by the purchaser to Pierce Arrow Inc. in Henrietta, Texas at the purchaser's expense. Any repairs not made by Pierce Arrow Inc. are not covered by the limited warranty and are the responsibility of the purchaser.

Pierce Arrow Inc. reserves the right to repair or replace defective parts or products in its sole discretion. The cost of any repairs not covered by the warranty will be charged to the purchaser.

EXCLUSIONS

All Pierce products are manufactured for a specific intended purpose. The Pierce Arrow Inc. limited warranty does not cover, and Pierce Arrow Inc. is not liable for, damage arising from any use other than the specific intended use of each product.

All coolers manufactured by Pierce are warranted for general cooling, and are not guaranteed to produce cooling sufficient for any specific purpose or for specific temperature. Pierce is not liable for any injury or damage arising from insufficiently cooled objects placed in the cooler, including but not limited to medications and perishables.

The Pierce Arrow Inc. limited warranty does not cover:

- Ongoing maintenance parts or repair due to normal wear and tear, and
- Any change or defect due to accident, misuse or any use for which the equipment was not intended, improper or unauthorized repair, failure to provide regular maintenance, and deterioration due to weather or road conditions.

Purchasers should consult their owner's manual for safety, installation, operation, and maintenance guidelines.

The Pierce Arrow Inc. limited warranty does not cover purchaser's cost of labor, transportation, shipping damages, installation or removal costs, down time, loss of profit or goodwill, or any other special, incidental, indirect, or consequential damages, concerning or related to any product or

part, whether based upon negligence, strict liability, breach of contract, breach of warranty, misrepresentation, or any other legal theory.

Merchandise manufactured by Pierce Arrow Inc. is not designed or intended for the movement of people and are not to be used in the operation of elevators or other improper uses. Any improper use of the product may void the warranty.

OTHER MANUFACTURERS' WARRANTIES

Pierce Arrow Inc. makes no warranty, expressed or implied, to finished products manufactured or supplied by other manufacturers, and sold by Pierce Arrow Inc. to the purchaser, including but not limited to, any vehicle to which our product is affixed and any accessories. Such merchandise is subject to the manufacturer's warranty only, which will be provided upon request.

CONDITIONS OF SALE

When placing an order with Pierce Arrow Inc., the terms and conditions provided for payment, shipping, delivery and claims create an agreement between the purchaser and Pierce Arrow Inc. The agreement is to be performed in Clay County, Texas.

RETURNS: No returns are accepted without prior authorization. All items must be returned in their entirety. Please contact a sales representative for authorization. Upon authorization, returns must be shipped freight prepaid and may be subject to a 15% restocking fee. Please do not send returns COD. No returns will be accepted later than 30 days from the date of invoice.

DAMAGED GOODS: Pierce Arrow Inc. is not responsible for, and has no liability for:

- Damage arising during shipment
- Any change or defect due to accident, misuse or any use for which the equipment was not intended, improper or unauthorized repair, failure to provide regular maintenance, and deterioration due to weather or road conditions.

CLAIMS: Claims for breakage or damages during shipment must be made to the carrier at the time of delivery. If a signature is required, you must notify the driver and sign that there was damage. You must notify Pierce Arrow Inc. of the damage promptly so that a claim can be filed.

Thank you for choosing Pierce!

We strive to offer 100% customer satisfaction on all our products. We are committed to excellent customer service because we are *pulling for you*.

SHARE YOUR FEEDBACK

Are you 100% satisfied?

- **If YES:** Please write a review on our Facebook page. www.facebook.com/piercearrowinc
- **If NO:** Call us at 800-658-6301 or let us know how we can help at www.piercearrowinc.com/contact-us

STAY IN TOUCH

Pierce Arrow Inc.
549 US Highway 287 South
Henrietta, Texas 76365

Toll Free: (800) 658-6301
Local: (940) 538-5643
Fax: (940) 538-4382

www.piercearrowinc.com
www.youtube.com/piercearrowinc