

PS9000 WINCH

included accessories on reverse

PIERCE

PULLING FOR YOU

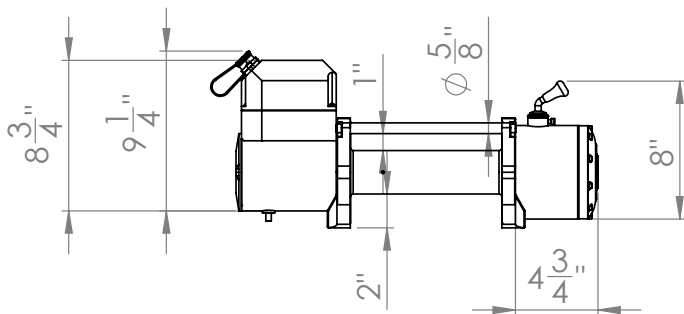
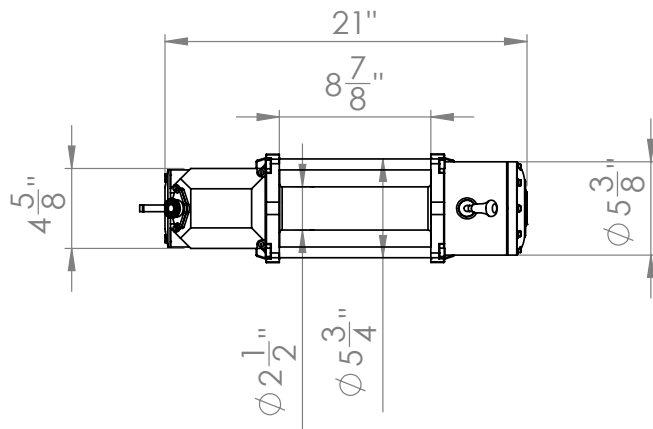
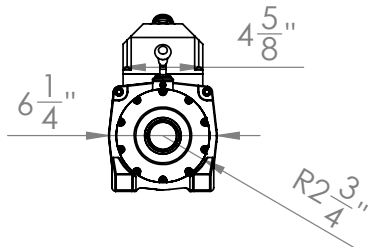
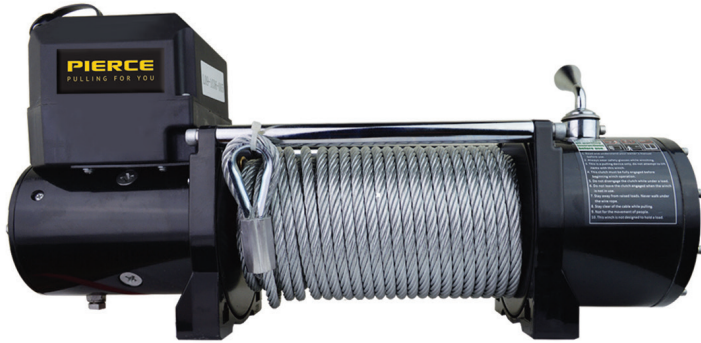

CATEGORY WINCH

PART NO. PS9000

PRODUCT DESCRIPTION

9,000 lb Self-Recovery Electric Winch

SPECIFICATIONS

RATED LINE PULL	9,000 lb
LINE SPEED	24 fpm
VOLTAGE	12 V
CONTROL	Remote with 15' lead
RATIO	265:1
MINIMUM WIRE GAUGE	2 gauge
RECOMMENDED BATTERY	650 CCA
MOTOR	5.5 hp
WINCH CONSTRUCTION	Cast metal
GEAR TRAIN	3-stage planetary
CLUTCH	Sliding ring gear
BRAKE	Automatic in the drum
ROTATION OF WINCH	CCW
DRUM SIZE	2.50" x 8.70"
MOUNTING PATTERN	4.5" x 10"
WIRE ROPE RECOMMENDED	3/8" x 94'
WINCH WEIGHT	84 lb
GROSS WEIGHT	91 lb
WINCH DIMENSIONS (LxWxH)	21" x 5.375" x 8.75"
BOX DIMENSIONS (LxWxH)	23" x 8.5" x 14"

LINE SPEEDS

LAYERS OF WIRE ROPE	RATED PULL (LB)	WIRE ROPE (FT)	LINE PULL (LB)	SPEED (FPM)	CURRENT
1	9,000	16.2	0	24.0	80 amps
2	7,320	39.3	4,000	10.6	240 amps
3	5,500	68.9	6,000	8.5	280 amps
4	4,750	91.8	8,000	7.0	330 amps
			9,000	6.5	360 amps

INCLUDED ACCESSORIES FOR PS9000 WINCH

PIERCE

PULLING FOR YOU



P040N PIERCE WIRED REMOTE CONTROL



SOLENOID ASSEMBLY



HOOK

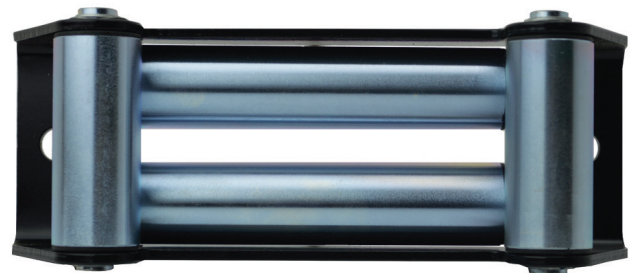

ROLLER GUIDE



SNATCH BLOCK



CABLE / WIRING